



Description



- Purifier of air and surface device for enclosed spaces which produces and spreads effectively hydroxyl radicals (OH⁻).
- Inactivates up to 99.9% of existing viruses, bacteria, allergens, mold, odors and volatile organic compounds (VOCs), according to studies carried out in universities and independent laboratories.
- Compact and smart design with rounded shapes and radius.
- Very low electric consumption: 3.6 watts per hour.
- Works with cartridges charged with hydrogen peroxide solution. Each cartridge has a 3 month lifetime.
- On average, it reaches about 50-60 square meters.
- Tactile keypad with buttons: ON/OFF, night mode and alarm indicators.
- Real time led which shows the air and surface contamination state inside the actuation zone.
- Very low sound level.
- The night mode turns OFF the led and reduces the device noise to make sleep easy.
- Without filters.
- To achieve a better and wider sanitizing action, it's recommended to place the appliance at a height of 1.5 meters from the ground, separated from corners at least 60cm and make easier the air circulation between all the rooms of the local/home.

Technical data

Model	Electrical Consumption 230V-50Hz W/h	Weight kg
WADU-02	3,6	1,9

Features

Easy control and compact design



Automatic Operation
Automatically purifies airborne and surface contaminants



Night Mode
Minimal noise,
Quiet functioning,
Low brightness for comfortable sleep



Cartridge Alarm
Lets you know in advance when you need replace cartridge



Alert
Notifies in case of empty cartridge or when improper inserting causes a stop in function



Dimensions

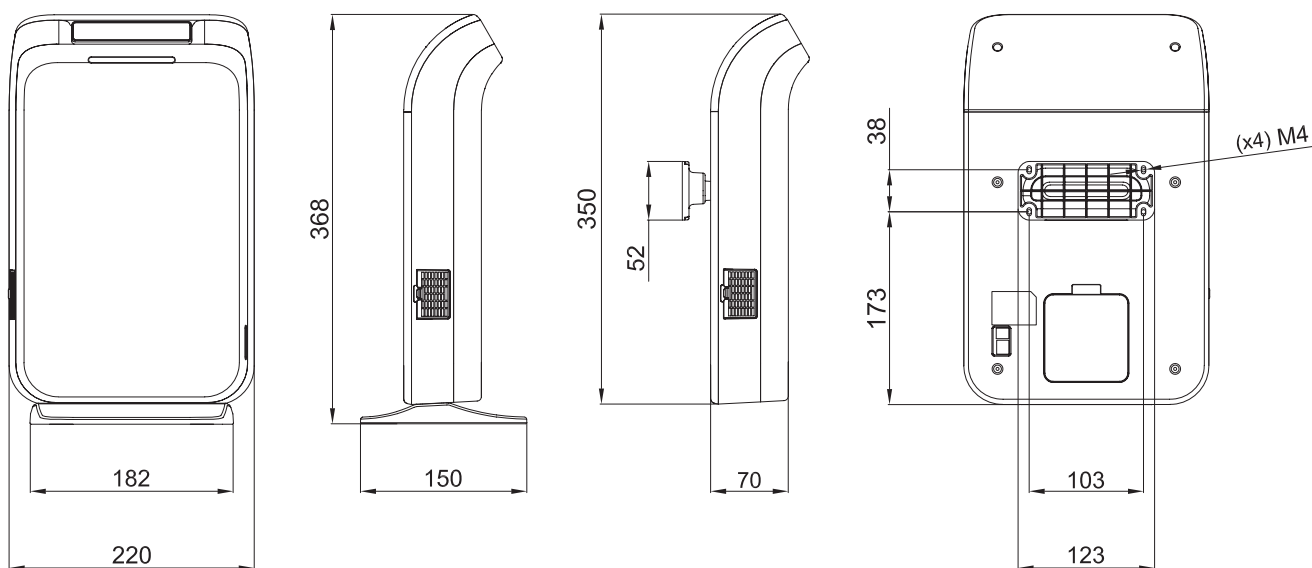

Security support

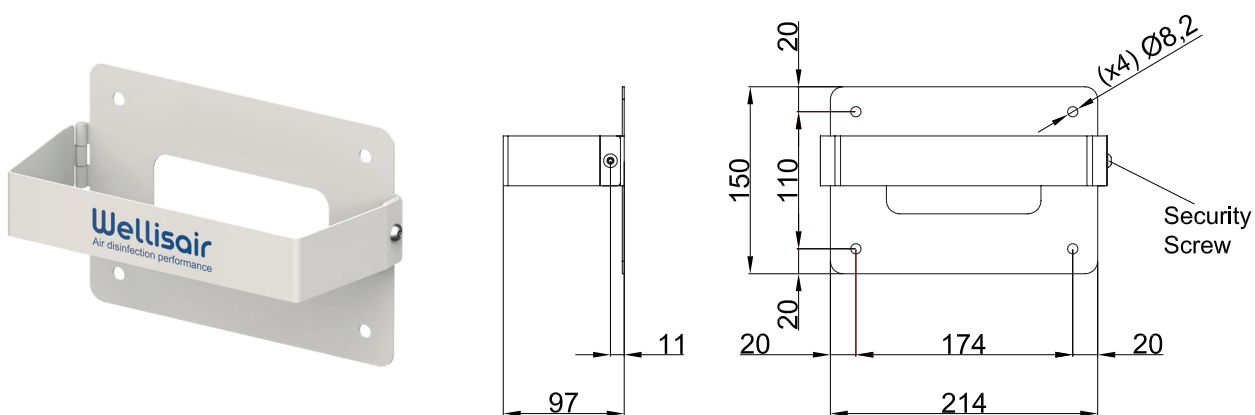

Replacements

Anyone can easily and conveniently replace the cartridge



You can enjoy top performance if you replace the cartridge every 3 months

(The operating life of consumable fluid cartridge varies depending on environment, including indoor temperature, humidity, etc.)