



Technical Features



RAL 9016 standard



Other colors on request



Range
Up to 4,2 m



Heating types
Heat Pump
Gas R32 / R410a



Casing
Galvanised Steel
Self-Supporting



Airflow / Length
1640 - 5110 m³/h
1m to 2,5m



Heating capacity
8 - 25 kW



Grille type
Suction lamellas with
pre-filter included



Fans
Centrifugal
5-speed



Control
Slave DX regulator
Consult other options



Outlet vanes
Aluminium, airfoil type
Adjustable

RECESSED WINDBOX is a high pressure compact and robust air curtain from our standard range with a timeless and visually pleasing design. It is specially designed for recessed installation in false ceilings. It is a suitable air curtain for all types of commercial entrances.

Air curtain with high energy saving heat pump for all types of commercial and industrial entrances, specially designed for installation in false ceilings. In heating, it reduces consumption and CO2 emissions by up to 70%.

Prepared to connect to SAMSUNG CAC heat pump (R32/R410) with direct expansion valve, included.

Sensors pre-installed in the direct expansion coil. As an option, under request, it can also work in cold mode (refrigeration), with optional condensate water pump. Efficient EC centrifugal fans with low consumption, double inlet with external rotor motor and low noise level. Internal pre-filter included.

Plug&Play Slave DX control programmable according to the door status. Consult other regulation options (slave or master).

Requires SAMSUNG CAC Interface KIT adapted for air curtain and programmable control, please consult.

AIR CURTAIN SPECIFICATIONS

Model	Airflow m ³ /h	Ventilation power 230V-50/60Hz	Ventilation current 230V-50/60Hz	Outdoor unit (*) 230Vx1	Outdoor unit (*) 400Vx3	Pipes gas-liquid inch	Noise level (5 m) dB(A)	Weight kg
		kW	A					
RECM 1000 DX8-SA	1640	0,142	1,24	AC71RXADNG/EU	-	5/8" - 3/8"	56	63
RECM 1500 DX11-SA	2460	0,213	1,86	AC100RXADKG/EU	AC100RXADNG/EU	5/8" - 3/8"	57	93
RECM 2000 DX19-SA	3280	0,284	2,48	-	AC200KXAPNH/EU	3/4" - 3/8"	58	122
RECM 2500 DX21-SA	4100	0,355	3,10	-	AC200KXAPNH/EU	3/4" - 3/8"	59	153
RECM 2500 DX24-SA	4100	0,355	3,10	-	AC250KXAPNH/EU	7/8" - 3/8"	59	153
RECG 1500 DX13-SA	2920	0,284	2,48	AC120RXADKG/EU	AC120RXADNG/EU	5/8" - 3/8"	62	98
RECG 2000 DX23-SA	4380	0,426	3,72	-	AC200KXAPNH/EU	3/4" - 3/8"	63	131
RECG 2500 DX25-SA	5110	0,497	4,34	-	AC250KXAPNH/EU	7/8" - 3/8"	64	163

(*) Direct expansion valve inbuilt in the outdoor unit

OUTDOOR UNIT SPECIFICATIONS

Outdoor unit model (*)	Heating capacity	COP o SCOP	Cooling capacity	EER o SEER	Power supply	Pipes gas-liquid	Pipes minimum - maximum length	Pipes maximum height
	kW		kW			inch	m	m
AC71RXADNG/EU	8	3,20	6,8	2,93	230Vx1	5/8" - 3/8"	5 - 50	30
AC100RXADKG/EU	11,2	3,20	10	2,90	230Vx1	5/8" - 3/8"	5 - 50	30
AC100RXADNG/EU	11,2	3,27	10	2,92	400Vx3	5/8" - 3/8"	5 - 50	30
AC120RXADKG/EU	13,2	3,42	12	2,66	230Vx1	5/8" - 3/8"	5 - 50	30
AC120RXADNG/EU	13,2	3,48	12	2,67	400Vx3	5/8" - 3/8"	5 - 50	30
AC200KXAPNH/EU	23	3,45	20	3,10	400Vx3	3/4" - 3/8"	5 - 75	30
AC250KXAPNH/EU	27	3,24	25	2,61	400Vx3	7/8" - 3/8"	5 - 75	30

Energy efficiency: SCOP/SEER seasonal ≤12kW, COP/EER >12kW.

Outdoor unit capacities depending on standard conditions: heating 20°CDB indoor / 7°CDB and 6°CWB outdoor, cooling 27°CDB and 19°CWB indoor / 35°CDB outdoor.

When adverse weather conditions, the outdoor unit capacity can decrease. It is recommendable to oversize the units.

(*) Outdoor units with R32 gas: ACxxxRXADNG/EU y ACxxxRXADKG/EU. Outdoor units with R410A gas: AC200KXAPNH/EU y AC250KXAPNH/EU.



Technical Features



RAL 9016 standard

Other colors on request



Range
Up to 4,2 m



Heating types
Heat Pump
Gas R410a



Casing
Galvanised Steel
Self-Supporting



Airflow / Length
1640 - 5110 m³/h
1m to 2,5m



Heating capacity
8 - 29 kW



Grille type
Suction lamellas with pre-filter included



Fans
Centrifugal
5-speed



Control
Slave DX regulator
Consult other options



Outlet vanes
Aluminium, airfoil type
Adjustable

RECESSED WINDBOX is a high pressure compact and robust air curtain from our standard range with a timeless and visually pleasing design. It is specially designed for recessed installation in false ceilings. It is a suitable air curtain for all types of commercial entrances.

Air curtain with high energy saving heat pump for all types of commercial and industrial entrances, specially designed for installation in false ceilings. In heating, it reduces consumption and CO₂ emissions by up to 70%.

Prepared to connect to SAMSUNG VRF outdoor heat pump unit (R410), not included, to be purchased by the customer.

Sensors pre-installed in the direct expansion coil. As an option, under request, it can also work in cold mode (refrigeration), with optional condensate water pump.

Efficient EC centrifugal fans with low consumption, double inlet with external rotor motor and low noise level. Internal pre-filter included.

Plug&Play Slave DX control programmable according to the door status. Consult other regulation options (slave or master).

Requires SAMSUNG VRF Interface KIT adapted for air curtain and programmable control, please consult.

AIR CURTAIN SPECIFICATIONS

Model	Airflow	Ventilation power	Ventilation current	Kit (*)	Pipes gas-liquid	Noise level (5 m)	Weight
	m ³ /h	230V-50/60Hz kW	230V-50/60Hz A		inch	dB(A)	
RECM 1000 VRF8-SA	1640	0,142	1,24	MXD-K025AN	5/8" - 3/8"	56	63
RECM 1500 VRF13-SA	2460	0,213	1,86	MXD-K050AN	5/8" - 3/8"	57	93
RECM 2000 VRF16-SA	3280	0,284	2,48	MXD-K050AN	5/8" - 3/8"	58	122
RECM 2500 VRF24-SA	4100	0,355	3,10	MXD-K075AN	7/8" - 3/8"	59	153
RECG 1000 VRF10-SA	2190	0,213	1,86	MXD-K025AN	5/8" - 3/8"	61	67
RECG 1500 VRF15-SA	2920	0,284	2,48	MXD-K050AN	5/8" - 3/8"	62	98
RECG 2000 VRF20-SA	4380	0,426	3,72	MXD-K050AN	3/4" - 3/8"	63	131
RECG 2000 VRF24-SA	4380	0,426	3,72	MXD-K075AN	7/8" - 3/8"	63	131
RECG 2500 VRF29-SA	5110	0,497	4,34	MXD-K075AN	7/8" - 3/8"	64	163

When adverse weather conditions, the outdoor unit capacity can decrease. It is recommendable to oversize the units.

(*) Direct expansion valve included with the kit.

The VRF-compatible models are as follows:

- DVM S
- DVM S Eco



Selection program



Dimensions

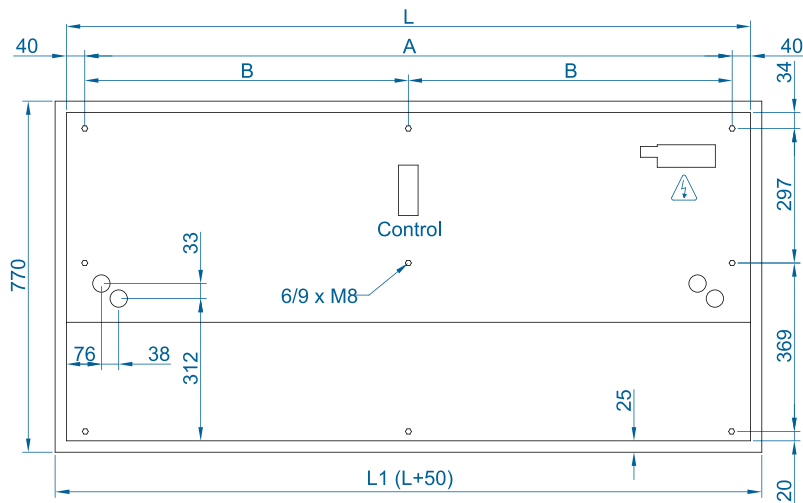

Model	L	L1	A	B
1000	1000	1050	920	-
1500	1500	1550	1420	710
2000	2000	2050	1920	960
2500	2500	2550	2420	1210

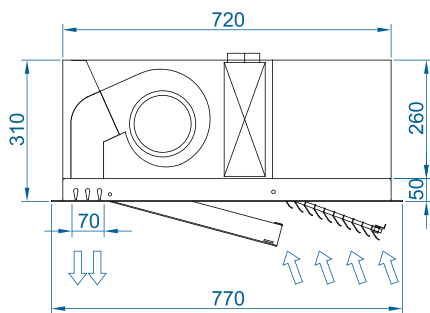

CAD drawings, BIM files, installation manuals and other documents



Accessories

Supports and installation



Wall rail support
SPWR



Silentblock supports
SPANG-SIL / SLB



Gripple hanger
SPCT



Slave DX
(Included)



Clever Control Kit



RJ45 Cable
(Included)



External Temperature
Sensor (Clever)

Sensors and valves



Magnetic door contact
DC



Mechanical door contact
DC



Condensate water pump
for DX air curtains