

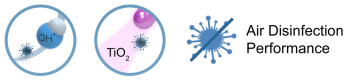

Characteristics

Kool air curtain for cold rooms with air and surface disinfection and purification function. It combines the Kleenfan and OH technologies which, through the effect of photocatalysis and the generation of OH-hydroxyl radicals, eliminate viruses, bacteria, odours and contaminating gases.



Air Disinfection Performance



- Combines a double patented purification technology through the generation of hydroxyl radicals OH· and the effect of photocatalysis.
- Innovative OH active technology with efficient production of hydroxyl radicals, complies with the exposure limits against chemical agents adopted by the National Institute of Safety and Health (INSS), which purifies both air and surfaces through a chain reaction. Through Advanced Oxidation Processes (AOP) inactivates up to 99.9% of pathogenic microorganisms (viruses and bacteria), improves air quality (reducing volatile organic compounds and suspended particles) and eliminates odours.
- Includes one purificant cartridge with hydrogen peroxide solution to generate hydroxyl radicals.
- Kleenfan technology with photocatalytic purificant action fans. UV-A rays, from the long-life led, act on the titanium dioxide of the turbine generation Reactive Oxygen Species (ROS) than, through oxidation /reduction reactions, inactivate wide range of pathogenic microorganisms (viruses and bacteria). It mineralizes most of the pollutants present in urban areas produced by vehicles and industry (NOx, SOx, COx, formaldehydes, VOCs, etc.).
- Includes Advanced Clever Control with purification program operation 24h/day, 4 levels of air quality indicator and replacement alarm of hydrogen peroxide purificant cartridge (around 3 months duration, depending on conditions). Plug&Play, programmable, Intelligent, automatic, energy saving mode, Modbus RTU by PLC...
- Specially designed to be installed in doors of cold stores and freezers.
- Self-supporting casing construction made of galvanized steel plate, finished in structural epoxy-polyester painting white colour RAL9016 as standard. Other colours or stainless steel are available on request.
- Large faceted inlet grille avoiding intensive maintenance. Also available with flat micro-perforated inlet grille, more elegant for commercial doors where heating is not needed.
- Anodized aluminium outlet vanes, airfoil shaped, adjustable from 0 to 15° each side.
- EC Double-inlet centrifugal fans driven by an external rotor motor and low noise level, with very low consumption efficiency fans.
- "A" type without heating, air only.

Specifications

50Hz

Model	Unheated	
	Nominal Airflow (m³/h)	Recommended Installation Height (m)
KECM 1000 A OH+FC	1840	2,5-3,8
KECM 1500 A OH+FC	2760	2,5-3,8
KECM 2000 A OH+FC	3680	2,5-3,8
KECM 2500 A OH+FC	4600	2,5-3,8
KECM 3000 A OH+FC	5520	2,5-3,8
KECG 1000 A OH+FC	2700	3-4,2
KECG 1500 A OH+FC	3600	3-4,2
KECG 2000 A OH+FC	5400	3-4,2
KECG 2500 A OH+FC	6300	3-4,2
KECG 3000 A OH+FC	7200	3-4,2

60Hz



Unheated		
Model	Nominal Airflow (m³/h)	Recommended Installation Height (m)
KECM 1000 A OH+FC	1840	2,5-3,8
KECM 1500 A OH+FC	2760	2,5-3,8
KECM 2000 A OH+FC	3680	2,5-3,8
KECM 2500 A OH+FC	4600	2,5-3,8
KECM 3000 A OH+FC	5520	2,5-3,8
KECG 1000 A OH+FC	2700	3-4,2
KECG 1500 A OH+FC	3600	3-4,2
KECG 2000 A OH+FC	5400	3-4,2
KECG 2500 A OH+FC	6300	3-4,2
KECG 3000 A OH+FC	7200	3-4,2

Dimensions

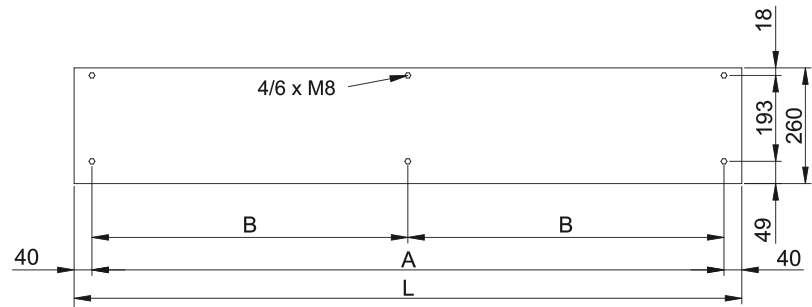
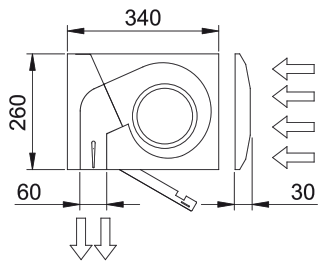

L	A	B
1000	920	-
1500	1420	710
2000	1920	960
2500	2420	1210
3000	2920	1460

