



Characteristics



- Energy saving heat pump air curtain: Up to 70% reduction in costs and CO2 emissions (heating mode).
- Self-supporting casing construction made of galvanized steel plate, finished in structural epoxy-polyester painting white colour RAL9016 as standard. Other colours or stainless steel are available on request.
- Micro-perforated inlet grille with filter functions and easy service. Internal prefilter included.
- Anodized aluminium outlet vanes, airfoil shaped, adjustable from 0 to 15° each side.
- EC Double-inlet centrifugal fans driven by an external rotor motor and low noise level, with very low consumption efficiency fans.
- Includes only heating direct expansion coil with installed temperature sensors. Under request it can be modified to work in cooling and heating mode (not recommended) with optional condensate water pump.
- Plug&Play control panel CS-5DX-NE slave DX with 5 speeds selector and 10m telephone cable included.
- Optional: Advanced Clever Control (programmable, automatic, intelligent, energy savings, Modbus RTU for BMS...) with special program to work in cooling mode which avoids water condensation. It regulates cooling power to maintain air speed and get the environments separation.
- DX 1:1:  
Ready to connect to LG Inverter outdoor heat pump unit (R410A/R32) with expansion valve, not included, the customer should purchase it.  
Requires LG DX Interface KIT adapted for air curtain and programmable control, please consult.
- DX VRF:  
Ready to connect to LG VRF outdoor heat pump unit (R410A) and expansion valve, not included, the customer should purchase it.  
Requires LG VRF Interface KIT adapted for air curtain and programmable control, please consult.

Specifications

50Hz

Heat Pump - DX 1:1					
Model	Nominal Airflow (m³/h)	Recommended Installation Height (m)	Outdoor Unit 230Vx1	Outdoor Unit 400Vx3	Heat pump connections
BB 1000 DX17-LG	3510	4-7	UUD1 U30 (60)	UUD3 U30 (60)	1" - 3/8"
BB 1500 DX24-LG	4680	4-7	-	UU70W U34	7/8" - 1/2"
BB 2000 DX34-LG	7020	4-7	2x UUD1 U30 (60) + UUD1 U30 (60)	2x UUD3 U30 (60) + UUD3 U30 (60)	5/8" - 3/8"
BB 2500 DX43-LG	8190	4-7	-	2x UU70W U34 + UU85W U74	1" - 3/8"
BB 3000 DX47-LG	9360	4-7	-	2x UU70W U34	1" - 3/8" // 5/8" - 3/8"

Heat Pump - VRF			
Model	Nominal Airflow (m³/h)	Recommended Installation Height (m)	Heat pump connections
BB 1000 VRF17-LG	3510	4-7	1" - 3/8"
BB 1500 VRF24-LG	4680	4-7	7/8" - 1/2"
BB 2000 VRF35-LG	7020	4-7	7/8" - 1/2"
BB 2500 VRF43-LG	8190	4-7	7/8" - 1/2"
BB 3000 VRF47-LG	9360	4-7	7/8" - 1/2"

60Hz

Heat Pump - DX 1:1			
--------------------	--	--	--



Model	Nominal Airflow (m³/h)	Recommended Installation Height (m)	Outdoor Unit 230Vx1	Outdoor Unit 400Vx3	Heat pump connections
BB 1000 DX17-LG	3510	4-7	UUD1 U30 (60)	UUD3 U30 (60)	1" - 3/8"
BB 1500 DX24-LG	4680	4-7	-	UU70W U34	7/8" - 1/2"
BB 2000 DX34-LG	7020	4-7	2x UUD1 U30 (60) + UUD1 U30 (60)	2x UUD3 U30 (60) + UUD3 U30 (60)	5/8" - 3/8"
BB 2500 DX43-LG	8190	4-7	-	2x UU70W U34 + UU85W U74	1" - 3/8"
BB 3000 DX47-LG	9360	4-7	-	2x UU70W U34	1" - 3/8" // 5/8" - 3/8"

Heat Pump - VRF				
Model	Nominal Airflow (m³/h)	Recommended Installation Height (m)	Heat pump connections	
BB 1000 VRF17-LG	3510	4-7	1" - 3/8"	
BB 1500 VRF24-LG	4680	4-7	7/8" - 1/2"	
BB 2000 VRF35-LG	7020	4-7	7/8" - 1/2"	
BB 2500 VRF43-LG	8190	4-7	7/8" - 1/2"	
BB 3000 VRF47-LG	9360	4-7	7/8" - 1/2"	

Dimensions

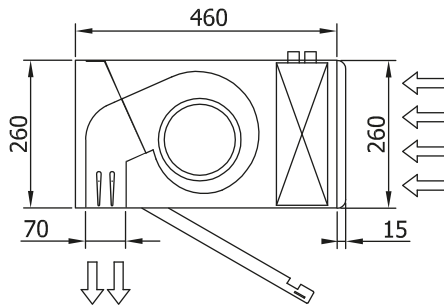
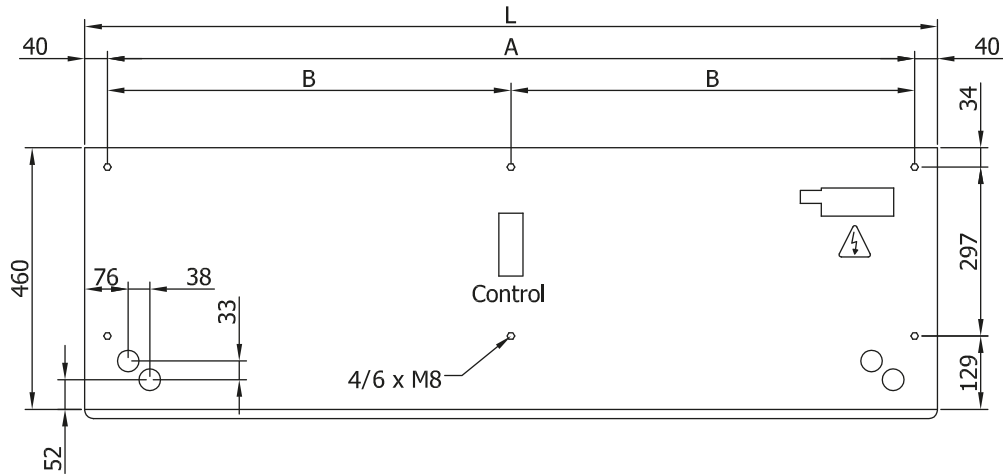

L	A	B
1000	920	-
1500	1420	710
2000	1920	960
2500	2420	1210
3000	2920	1460