

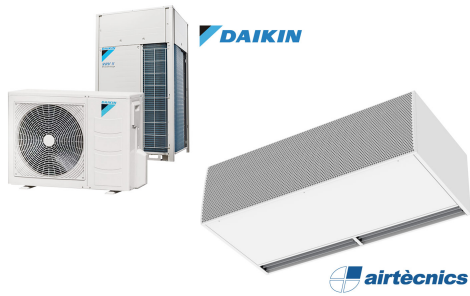

Characteristics



- Energy saving heat pump air curtain: Up to 70% reduction in costs and CO2 emissions (heating mode).
- Self-supporting casing construction made of galvanized steel plate, finished in structural epoxy-polyester painting white colour RAL9016 as standard. Other colours or stainless steel are available on request.
- Two frontal grille options: Industrial perforated (by default), commercial microperforated. Internal prefilter included.
- Anodized aluminium outlet vanes, airfoil shaped, adjustable from 0 to 15° each side.
- Low noise double-inlet centrifugal fans with external rotor motor. 5-speed controller.
- Includes only heating direct expansion coil with installed temperature sensors. Under request it can be modified to work in cooling and heating mode (not recommended) with optional condensate water pump.
- Plug&Play control panel CS-5DX-NE slave DX with 5 speeds selector and 10m telephone cable included.
- DX 1:1:
Optional: Advanced Clever Control (programmable, automatic, intelligent, energy savings, Modbus RTU for BMS...) with special program to work in cooling mode which avoids water condensation. It regulates cooling power to maintain air speed and get the environments separation.
Ready to connect to DAIKIN Inverter outdoor heat pump unit (R410A) and expansion valve, not included, the customer should purchase it.
Requires DAIKIN DX Interface KIT adapted for air curtain and programmable control, please consult.
- DX VRV:
Ready to connect to DAIKIN VRV outdoor heat pump unit (R410A) and expansion valve, not included, the customer should purchase it.
Requires DAIKIN VRV Interface KIT adapted for air curtain and programmable control, please consult.

Specifications

50Hz

Heat Pump - DX 1:1				
Model	Nominal Airflow (m³/h)	Outdoor Unit 230Vx1	Outdoor Unit 400Vx3	Recommended Installation Height (m)
L 1000 DX18-DA	3525	ERQ 140 AV1	-	4-5
L 1500 DX24-DA	5300	-	ERQ 200 AW1	4-5
L 2000 DX34-DA	7050	2x ERQ 125 AV1 + ERQ 140 AV1	-	4-5
L 2500 DX43-DA	8800	2x ERQ 140 AV1	2x ERQ 200 AW1	4-5
L 3000 DX49-DA	10600	-	2x ERQ 200 AW1 + ERQ 200 AW1	4-5
XL 1000 DX23-DA	4550	-	ERQ 200 AW1	5-7
XL 1500 DX34-DA	6850	2x ERQ 125 AV1 + ERQ 140 AV1	-	5-7
XL 2000 DX47-DA	9100	-	2x ERQ 200 AW1	5-7
XL 2500 DX57-DA	11400	-	2x ERQ 200 AW1 + ERQ 250 AW1	5-7
XL 3000 DX57-DA	13600	-	2x ERQ 250 AW1 + ERQ 250 AW1	5-7

Heat Pump - VRV		
Model	Nominal Airflow (m³/h)	Recommended Installation Height (m)
L 1000 VRV19-DA	3525	4-5
L 1500 VRV29-DA	5300	4-5

Heat Pump - VRV		
Model	Nominal Airflow (m³/h)	Recommended Installation Height (m)
L 2000 VRV34-DA	7050	4-5
L 2500 VRV43-DA	8800	4-5
L 3000 VRV49-DA	10600	4-5
XL 1000 VRV23-DA	4550	5-7
XL 1500 VRV34-DA	6850	5-7
XL 2000 VRV47-DA	9100	5-7
XL 2500 VRV61-DA	11400	5-7
XL 3000 VRV74-DA	13600	5-7

Dimensions

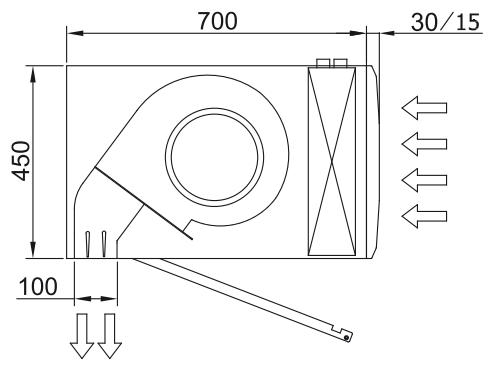
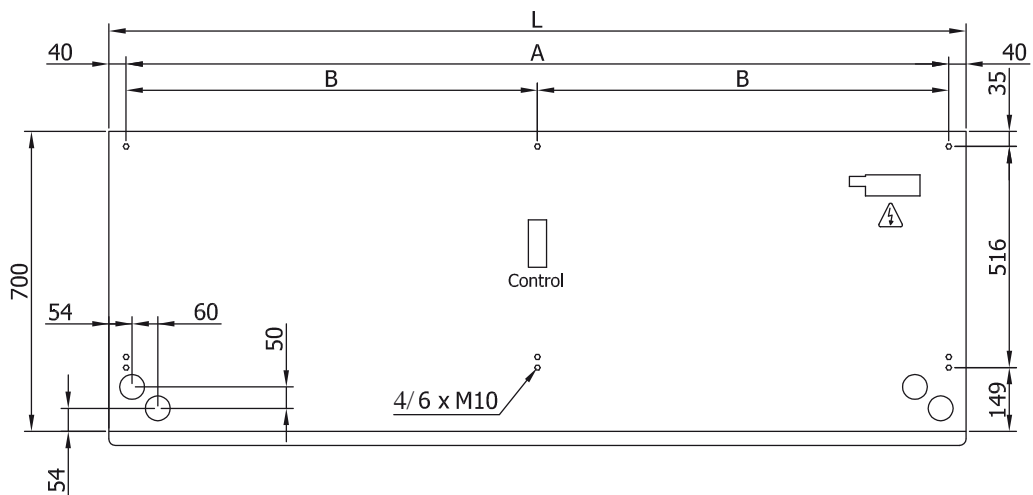

L	A	B
1000	920	-
1500	1420	710
2000	1920	960
2500	2420	1210
3000	2920	1460